



Panel-PC - Panelmount

HAWK SL 15-BT

- Intel® Baytrail SoC Processor J1900 New Atom
- max. 8GB DDR3L
- Capacitive



Form factor	3.5" SBC (5.8-in x 4.0-in)
Screen diagonal	15"
Aspect ratio / resolution (max.)	4:3 / 1024 x 768
Touch	PCT (Capacitive)
Protection class	IP65, front
Front	Aluminium silver
CPU	Intel® Baytrail SoC Processor J1900 New Atom, 10W
Chipset	SOC
RAM	max. 8 GB DDR3L, SO-DIMM, 1333 MHz
Storage interface	1x 2.5" SATA slot 1x mSATA slot
Ports	2x GigE 2x USB 3.0 1x VGA, 1920 x 1200; 1x HDMI 1.4a 1x Line-out 1x COM (RS-232/422/485) Intern: 6x USB 2.0 1x TPM Header Option: 3x COM (RS-232)
DIO	4x GPI + 4x GPO
Expanded interfaces	1x mini-PCIe, half size with PCIe x1 and USB 2.0
Watchdog timer	Output: From Super I/O to drag RESETCON# Interval: 256 segments, 0,1,2...255sec/min
Cooling system	Passive, fanless
Mounting	Panel mounting; VESA 75 x 75

Power input	9V to 36V DC
Power consumption	TBA
Operating system	Option: Windows® 10; Windows® 10 IoT Enterprise LTSB; LINUX
Max. color	16.7M
Luminance /cd/m²	400
View angle / H/V	160° / 160°
Backlight lifetime / hrs	50,000
Contrast ratio	500:1
Operating temperature	0° to 50°C
Storage temperature	-40°C to 85°C
Storage humidity	5% to 90%
Certificate	CE
Dimensions / mm	371.6 x 295.6 x 55
Weight / kg	ca. 3.1
Scope of delivery	3-pin terminal block connector; retaining clip; touch pen; on/off button; driver CD

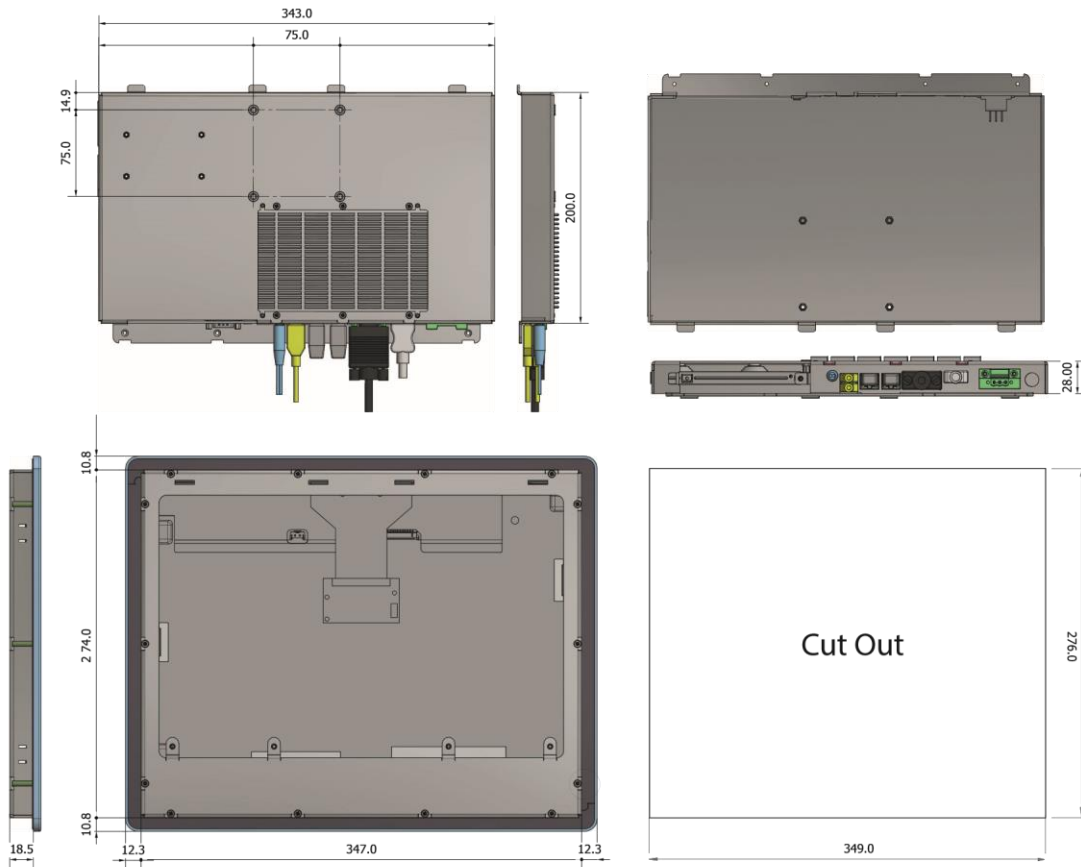

Order Information

HAWK SL 15-BT

510200.1